

Electric Actuators and Control Systems

rotork® Controls

Established Leaders in Valve Actuation

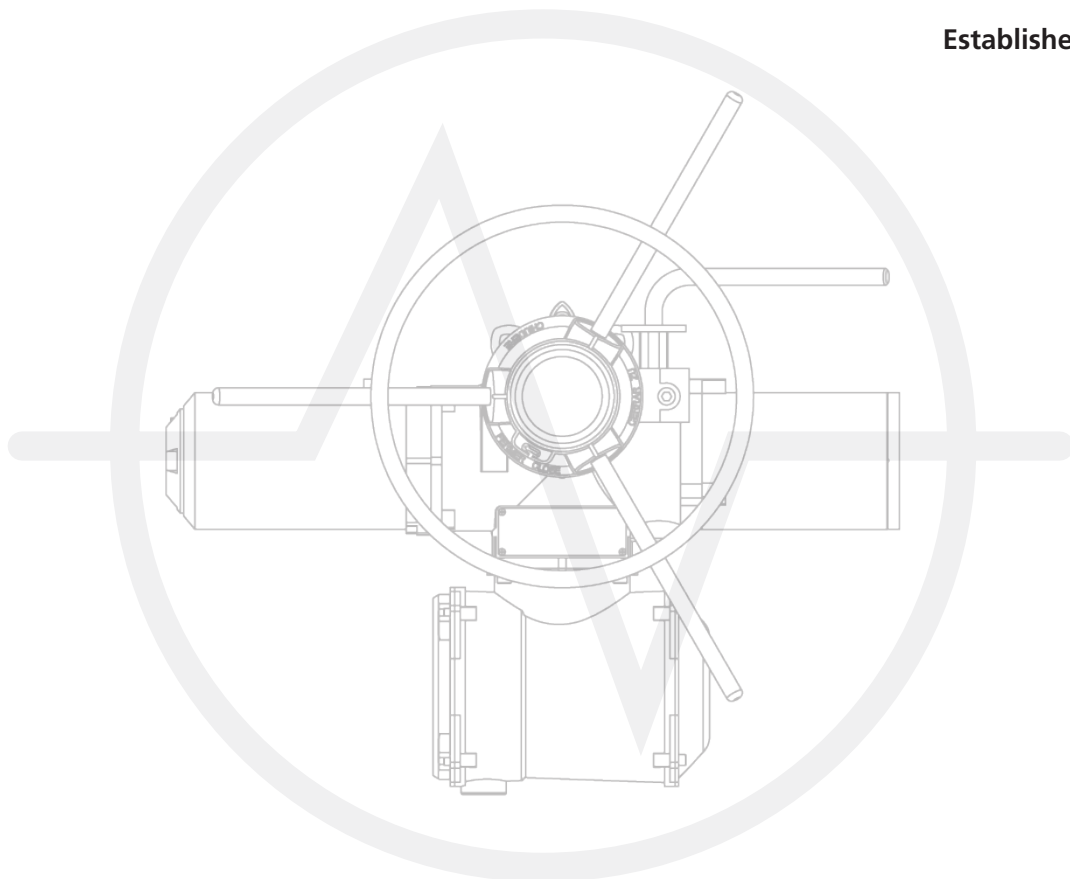

AWT Range

Control and Monitoring Facilities

Publication E320E Issue 10/08

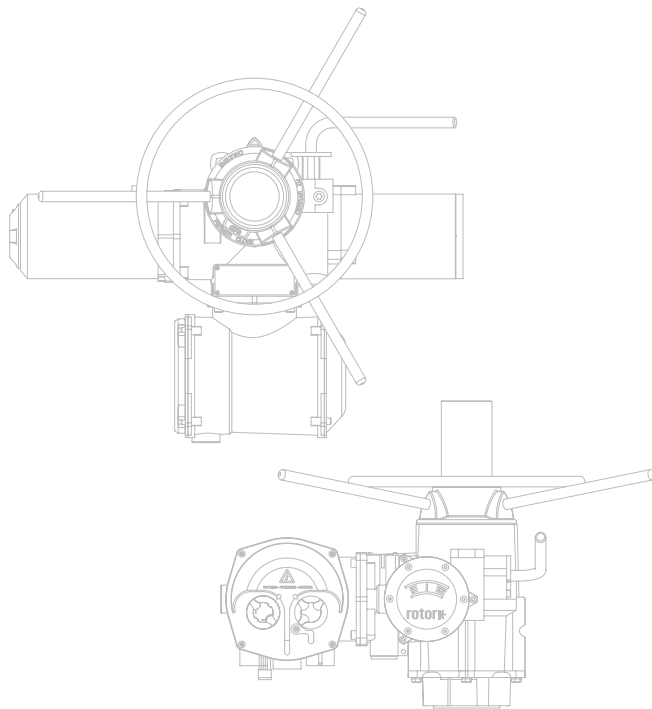

Contents

General electrical specification	4
Torque - limit switch mechanism	5
Add-on-Pak additional indication	6
SyncroSET specification	7
SyncroSET basic wiring diagram	8
SyncroSET options and number code	9
SyncroPAK specification	10
SyncroPAK options	11
SyncroPAK basic wiring diagram	12
SyncroPAK options and number code	13
SyncroPAK remote control circuits	14

With over fifty years experience of long-term installations in all environments, Rotork have evolved a design of uncompromising reliability. Today, Rotork actuation equipment is ahead of the field in valve operating and safety applications for industry.

Electric actuators provide the means of applying centralised control to valves, sluice gates and dampers. As part of the process routine or in an emergency, where there is risk to life, the environment or damage to plant, operational reliability of the valve is essential.

The actuator is the meeting point of the three elements of process control – valve, electrical power and control instrumentation. Each element has unique engineering requirements, brought together with design excellence at the interface – the AWT actuator.

Through design, development and production, actuators are tested to the limit. Design life testing, environmental, vibration as well as electrical testing are all carried out. Every unit is production proven on test rigs to check torque, electrical and mechanical operation and customer control and indication interface.

The AWT Range

The AWT Range

AWT Range actuators combine the qualities of a robust 3-phase electric motor and a well proven mechanical drive of the utmost simplicity combined with limit switching and a choice of indication options.

Available with or without integral motor starter, users control and instrumentation requirements can be met economically with standard, specified components.

Procurement is simplified with reduced plant design engineering and installation time achieved by standardisation of control and indication features inherent in the AWT.

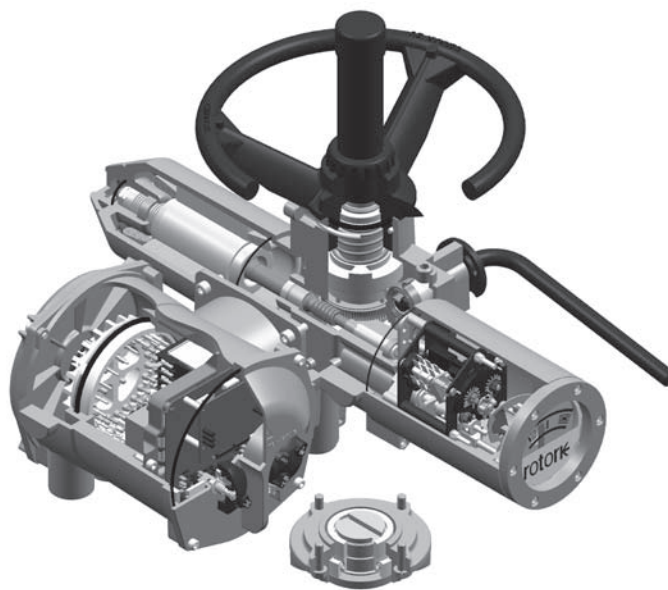

The AWT is available in two basic electrical forms - with or without integral motor control:

Non integral motor control – AWT SyncroSET

Actuator for operation of valves and dampers, comprising 3-phase motor, reduction gearbox, valve attachment with detachable drive component, limit and torque switches and terminal compartment. SyncroSET actuators must be used in conjunction with reversing contactors procured and installed by the user.

Integral motor control – AWT SyncroPAK

Self contained actuator for operation of valves and dampers. Comprising 3-phase motor, integral reversing contactor starter with local controls and remote control facilities, reduction gearbox, valve attachment with detachable drive component, limit and torque switches and separate terminal compartment. SyncroPAK require only a 3-phase supply for local electrical operation.

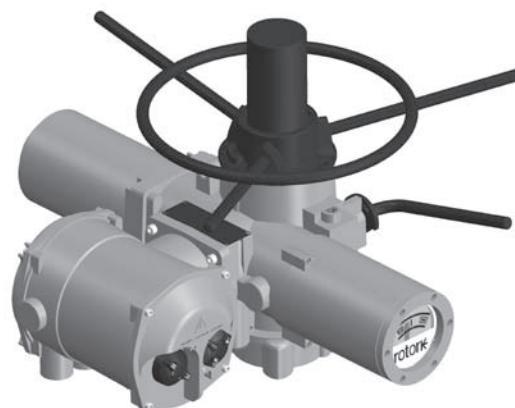
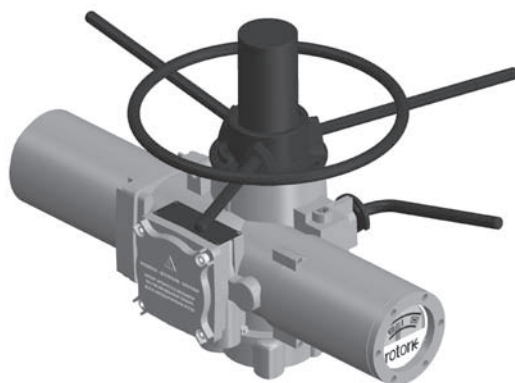

Actuator electrical specification

General

AWT range of actuators are designed for the electrical operation of valves, penstocks and dampers located in non-hazardous locations. Comprising 3-phase motor, reduction gearbox, valve attachment with detachable drive component, limit and torque switches and terminal compartment. The SyncroPAK version includes a motor starter assembly.

Enclosure

AWT actuators are rated:
IP68 7 metres 72 hours
NEMA 4, 4X and 6.
CSA WT.

All covers incorporate "spigot" sleeved joints with "O" ring seals. Actuators are suitable for use in ambient temperatures ranging from -30° to +70°C.

For temperatures outside this range please apply.

Power Supply

AWT actuators are suitable for operation with the following 3-phase, 3 wire nominal power supplies:

50Hz

220, 240, 380, 400, 460, 500, 525 and 550 Volts.

60Hz

208, 220, 230, 240, 380, 440, 460, 480, 575 and 600 Volts.

The required operating voltage must be specified at the time of order.

Actuator performance is guaranteed with a voltage tolerance +/-10% and a frequency tolerance +/-5 Hz. Actuators are capable of starting and running up to speed with a maximum 15% volt drop. For power supply tolerance or volt drop in excess of those stated above, please apply.

Uninterruptable Power Supplies - UPS

AWT actuators are suitable for use with UPS Power supplies provided the tolerances specified above are not exceeded. UPS output should adhere to recognised supply standards such as EN50160.

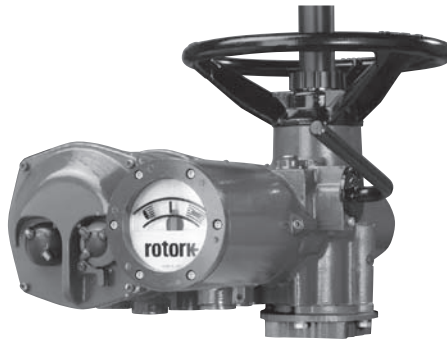

Motor

The integral 3-phase squirrel cage induction motor is specially designed for valve actuation. Class F insulated with winding thermostat, the low inertia, high starting and stalling torque motor provides substantial reserves of power to assure torque switch operation at maximum setting with a voltage reduction as much as 10% below nominal.

Due to the low inertia design and lost motion or "hammerblow" drive, starting is instantaneous within 3 cycles of the mains frequency. Motors are 15 minutes rated with a cyclic duration factor of 25% at 33% of actuator output rated torque giving a temperature rise not exceeding that permitted for class B insulation at standard nominal voltage.

Actuators are rated S2/S3 to IEC60034-1, 60 starts per hour at a rate not exceeding 600 starts per hour. Where long running times or regulation in excess of that stated above are required alternative motor insulation class and rating are available. Please apply.

Motor Thermostat

The motor thermostat enables the control circuit to be tripped and motor disconnected if the maximum permitted winding temperature is reached.

This protection is independent of ambient temperature variation and motor current, providing optimum usage of motor thermal capacity. The thermostat will auto reset on motor cooling.

For SyncroSET actuators it is vital that the motor thermostat is connected in series with the motor reversing contactor coils.

Refer to SyncroSET basic wiring diagram, page 8.

Torque-Limit Switch Mechanism

The unique combined torque and travel limit switch mechanism allows the actuator to be fitted to any valve type.

Actuator wiring diagrams do not vary with valve type.

Simple mechanical selectors for torque or limit tripping to suit both seating (torque) or non seating (position limit) type valves. Independent selectors for both opening and closing torque switch trip level.

The valve turns range is set by lead screw adjustment that mimics actuator output turns range.

In addition two open and two close auxiliary switched are provided as standard for remote end of travel indication or interlocking.

A mechanical 3 position pointer and dial provides local valve close, intermediate and open position indication.

Refer to page 5 for full description.

Wiring and Terminations

Jig built harnesses of individually stranded conductors, tropical grade PVC insulated, connect internal components to the terminal compartment. All wires are identified with printed numbers.

Refer to Syncroset and Syncropak specifications for details of user termination.

Every AWT actuator is despatched with the Installation and Maintenance Manual, publication E370E and wiring diagram.

Torque-Limit Switch Mechanism

Valve Control - Reliability to the limits

At the heart of reliable valve control is the ability of the actuator to move on demand and, more importantly, to stop at the exact position needed for valve sealing. Position limit switching must be 100% reliable and repeatable.

Position indication to the control centre must exactly reflect valve status. Torque protection for the valve must take priority and be easily selectable for both valvemaker and site maintenance personnel.

The AWT switch mechanism has been doing this job with complete reliability for over 30 years. The unique design allows simple limit set-up by lead screw adjustment, independent selectors for open and close torque overload setting and selection of "torque" or "position limit" valve seating.

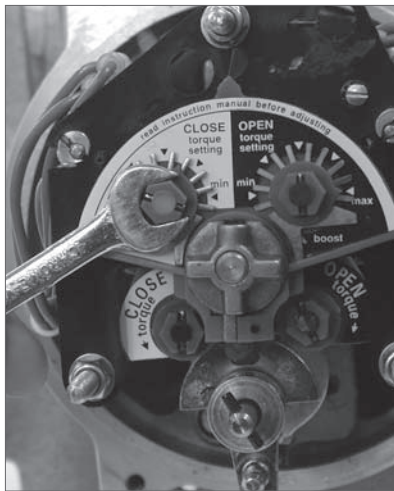

Advantages

- Actuator wiring diagram does not vary with valve type.
- Simple set up – mechanical selection, no electrical variations.
- Standard mechanism regardless of valve type, actuator size or control and indication scheme.
- Two open and two close auxiliary switches as standard for indication or interlocking.
- "Anti-hammer" and "torque switch bypass" protection as standard

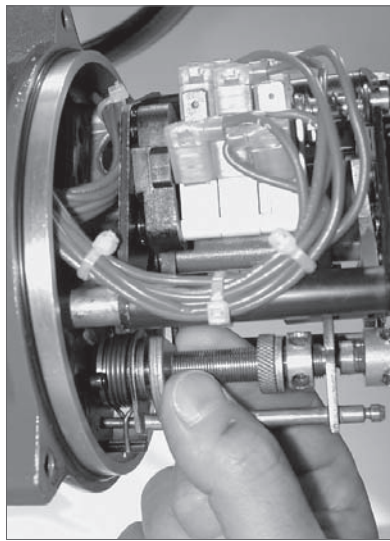

Key Features

Six switches arranged in two banks of three are provided. One bank is dedicated for closed (closing) and the other open (opening).

In each bank the two inboard switches are auxiliary switches for indication or interlocking - OAS 1 & 2 (open auxiliary switch) and CAS 1 & 2 (close auxiliary switch).

The outboard switch in each bank is the torque/limit switch - CT/LS (close torque/limit switch) and OT/LS (open torque/limit switch).

One switch is provided for both the limit and torque function as, electrically, only one switch is required to open and de-energise the contactor.

- Independent mechanical selection of torque trip level for opening and closing. Range 40% ("min") to 100% ("max").
- Torque protection always has priority.
- Independent mechanical selection of end of travel action:
 - Seating valve types, such as wedge gate, "Torque" is selected.
 - Position Limit type valves such as parallel slide, "Limit" is selected.
- Automatic mechanical latch prevents "torque switch hammer" when seating and unwanted torque trip during unseating.
- Positive auxiliary indication switching irrespective of valve type and end of travel action.
- Local "Open", "Intermediate" and "Close" valve position indication (illuminated on SyncroPAK).

Specification

Switches - All switch mechanism contacts are changeover type rated at 15A (inductive), 250V AC, 10A 30V DC. Silver/ silver cadmium butting contacts with a coil spring changover mechanism giving a mechanical life in excess of 10 million operations.

Please note that when fitted within the actuator, switch loading will be limited to 5A, AC or DC maximum unless otherwise specified.

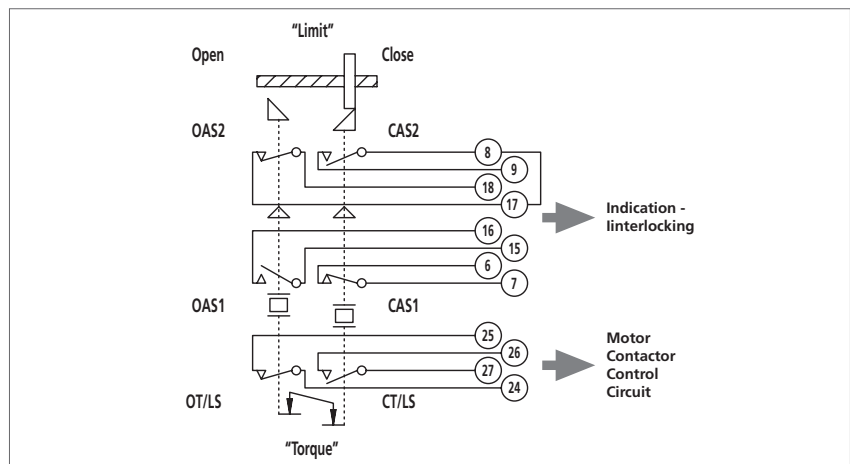

Add On PAK - AOP - Additional Indication Options

Add On PAK - AOP - Additional Indication Options

Innovative new design based on simple, proven technology the Add on Pak is an optional extra and provides a range of indication options in addition to the standard switch mechanism:

- Actuator wiring diagram does not vary with valve type.
- Continuous local valve indication - mechanical cover indicator.
- Additional auxiliary switches for valve indication or interlocking.
- Remote analogue valve position indication - voltage (potentiometer) or current (Current Position Transmitter - CPT).

Gear driven from the switch mechanism, the Add on Pak can be factory fitted or retrofitted after site installation if plant indication requirements change. The AOP can be fitted to any AWT SyncroPAK or SyncroSET actuator.

The AOP is available in various builds:

Basic	Continuous cover indication only.
Pot only	Basic + Potentiometer* for remote analogue indication.

2 switch	Basic + 2 independently operated auxiliary switches.
2 switch + Pot	Basic + 2 independently operated auxiliary switches + Potentiometer*.
6 switch	Basic + 6 independently operated auxiliary switches.
6 switch + Pot	Basic + 6 independently operated auxiliary switches + Potentiometer*.

* Potentiometer or CPT - specify.

Specification

Potentiometer – 1K or 5K Ohm (specify), 1 Watt rated, wire wound, single turn potentiometer. Linearity 1% typical.

Current Position Transmitter CPT – actuator powered (SyncroPAK only) or customer powered from a 14-40V DC supply (SyncroPAK and SyncroSET), driven by a multi-turn potentiometer with zero and span adjustment giving a settable range of 3.22–30mA.

Maximum external impedance at 15V DC is 500 Ohms.

The CPT is factory configured to optimise accuracy and repeatability (typical 1%) and therefore the valve turns range (open to close) must be specified with order.

Switches – All AOP auxiliary switch contacts are changeover type rated at 15A (inductive), 250V AC, 10A 30V DC. Silver/ silver cadmium butting contacts with a coil spring changeover mechanism giving a mechanical life in excess of 10 million operations. Please note that when fitted within the actuator, switch loading will be limited to 5A, AC or DC maximum unless otherwise specified.

Switches can be set as additional end of travel indication or to trip at any point in travel. Switch cams are finger adjusted and spring loaded for security.

Cover indication – mechanical pointer/dial indicating valve open, valve closed and intermediate points between.

Refer to pages 9 & 13 for AOP wiring diagram information.

Blinker – valve running indication is available as an option via a make/break volt free contact. Contact rating as above.

Standard Switch Mechanism

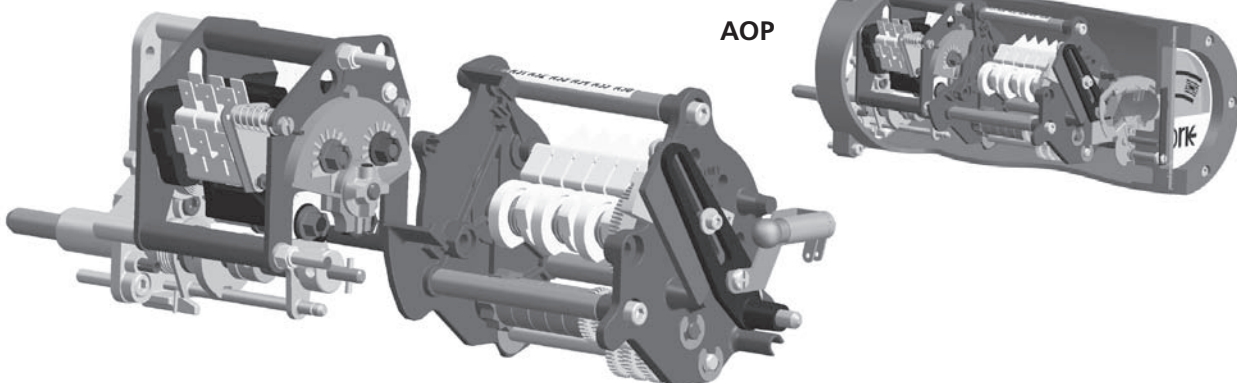

Principal of Operation

The Add On Pak is a self contained unit that “bolts on” to the standard switch mechanism. The limit switch drive provides the input to the AOP, being directly proportional to the valve turns. The AOP gear cluster pak then adjusts the inputs turns to optimise the AOP drive for switches, potentiometer and cover indicator. Adjustment is simple and can be carried out in the field by adding to, or taking gears and drive spacers away from the cluster. If valve turns range is specified with order the AOP will be factory set.

AWT SyncroSET - Control & Indication Specification

Non integral motor control –

AWT SyncroSET

Where a new installation requires motor control from the users motor control centre (MCC), or existing installations already incorporating a MCC, the AWT SyncroSET provides the basic components for valve actuation.

Comprising 3-phase motor, reduction gearbox, valve attachment with detachable drive component, limit and torque switches plus end of travel auxiliary indication switches and anti condensation heater. All internal wiring is brought out to the actuators terminal compartment ready for integrating into the MCC control system. SyncroSET actuators may only be used in conjunction with reversing contactors procured and installed by the user.

SyncroSET actuators are particularly suitable for installations where equipment at the valve location must be minimised, for example where ambient temperature, vibration or space provide restriction.

SyncroSET AWT actuators are standard sealed IP68 with double sealing available as an option.

Conduit Entries

- Standard sealed 10A to 35A – 3 x M32 or 3 x 1" ASA NPT. (specify). Fourth entry available as an option – apply.
- Double sealed 10A to 35A - 3 x M32 or 3 x 1" ASA NPT. (specify). Fourth entry available as an option – apply.
- Double sealed 40A to 95A - Conduit entries: 2 x M32 plus 1 x 40mm or 2 x 1" ASA NPT plus 1 x 1.5" ASA NPT (specify).

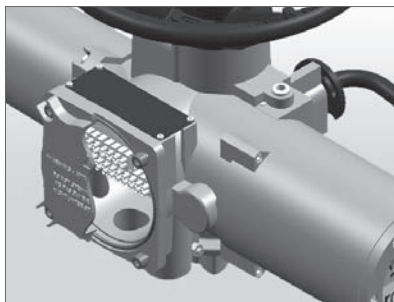

Heater

12W max. Unless specified, actuators built for 60Hz motor supplies will be fitted with a 120V (2K Ohm) heater and for 50Hz motor supplies 230V (5.6K Ohm).

Switch Mechanism

Provides torque switch protection, position limit and auxiliary indication switches. Standard 3 position local indication. Refer to page 5 for detail and page 8 for SyncroSET wiring diagram.

Syncroset enclosure, control and indication options

Standard sealed (10A to 35A only)

- Spigot (sleeve) jointed covers with "O" ring sealing.
- 3 conduit entries provided.
- All internal wiring brought to terminal connection strips.

Double sealed

- Spigot (sleeve) jointed covers with "O" ring sealing. Terminal compartment sealed from motor and switch mechanism compartments by IP68 terminal bung.
- 3 conduit entries provided in separately sealed terminal compartment.
- All internal wiring brought to terminals.

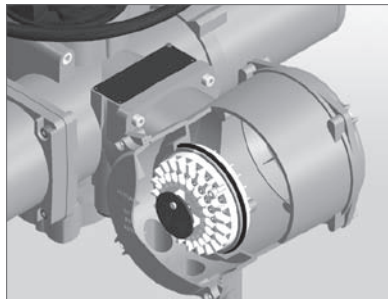

Double sealed plus local Control Station (LCS)

- Spigot (sleeve) jointed covers with "O" ring sealing. Terminal compartment sealed from motor and switch mechanism compartments by IP68 terminal bung.
- 3 conduit entries provided in separately sealed terminal compartment.
- All internal wiring brought to terminals.
- Control station provides lockable local, stop and remote control selector plus local open, close stop selector. Selector switches rated at 15A 250V AC/30V DC.

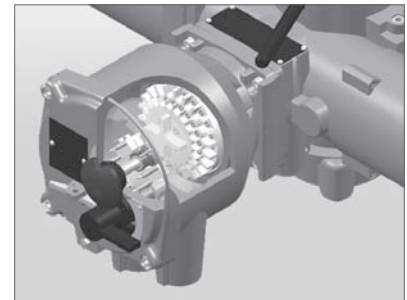

Additional valve indication – Option Add on Pak

The Add on Pak provides local mechanical valve indication plus a range of indication auxiliary switch and remote analogue valve position indication options. For further information on the Add on Pak refer to page 6.

Blinker – valve running indication is available as an option via a make/break volt free contact. Refer to Add-on-Pak, page 6.

AWT SyncroSET - Basic Wiring Diagram 2220-00

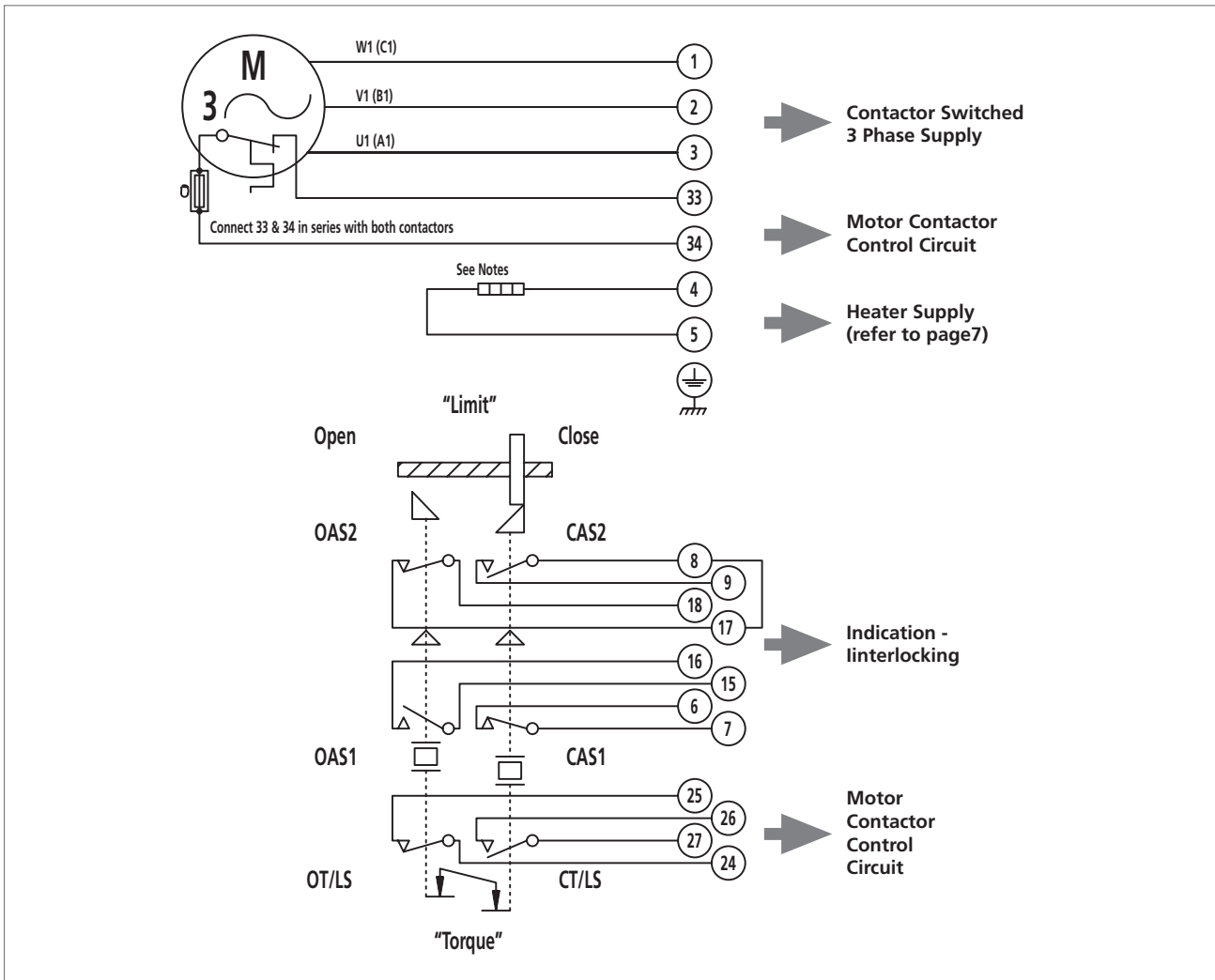

Notes:

○ User connection terminal

— Link Supplied By Rotork

Motor thermostat provides motor over temperature protection and must be wired in series with both contactor coils. Thermostat rating 70VA max.

Connect OT/LS in series with open contactor coil and CT/LS in with close contactor coil.

Switch Mechanism (refer to page 5)

- O = Open position
- C = Close position
- T/LS = torque/Limit Switch
- = contact made

Switch	Valve Open	Intermediate	Valve Close
OT/LS		■	■
CT/LS	■		
OAS1	■		
CAS1			■
OAS2		■	■
CAS2	■	■	

AWT SyncroSET - Options & Number Code

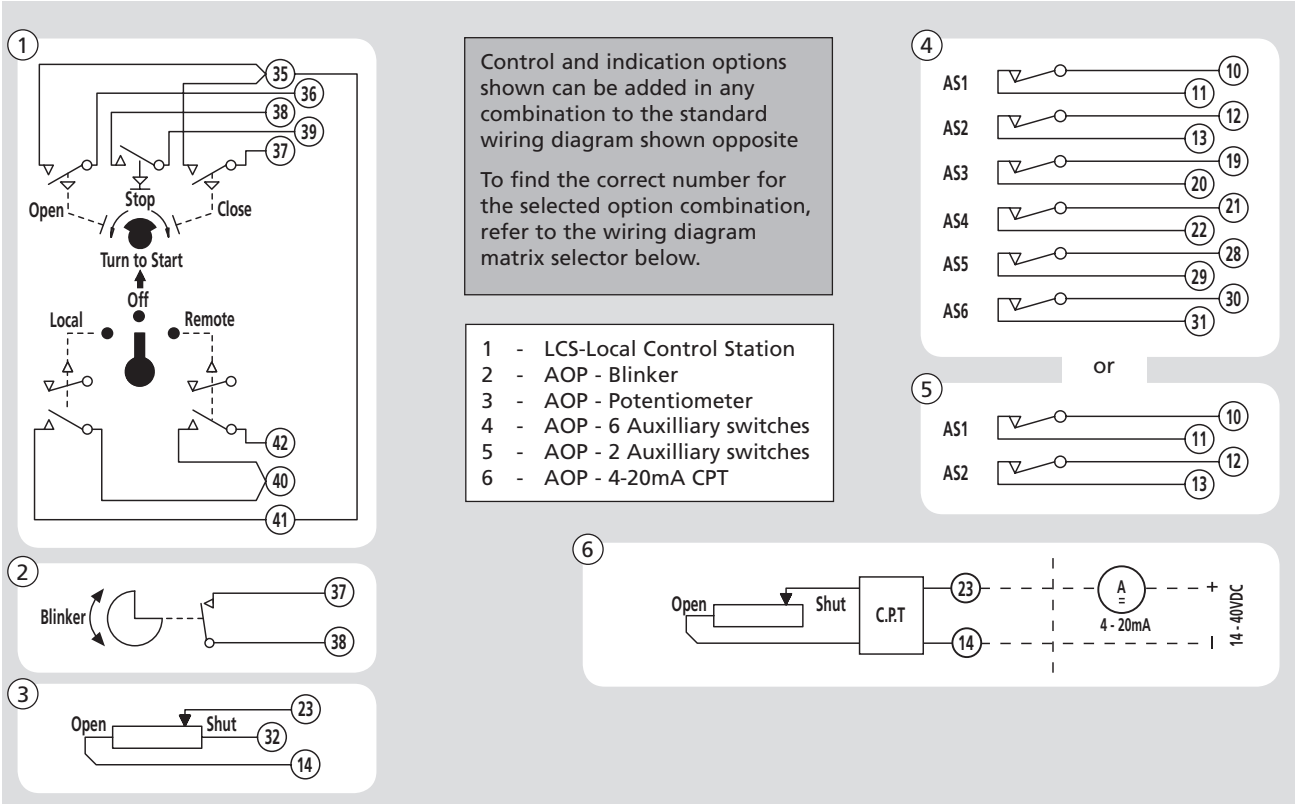

BASIC SyncroSET WIRING DIAGRAM 2220-00 IS SPECIFIED AS FOLLOWS:

Basic SyncroSET, not including a local control station with a standard switch mechanism (Open & close torque limit switches plus 2 open and 2 close auxiliary switches), no additional auxiliary switches, potentiometer or analogue CPT are included. Use the matrix below to select the wiring diagram for the required options.

Example: If 2 extra auxiliary switches are required the wiring diagram number changes to 4225-00.

Wiring diagram number	2	2	2	0	-	0	0
Additional Indication - Add on Pak							
2 Basic SyncroSET							
4 Basic SyncroSET + Option Add-on-Pak							
Local Control Station - Option LCS							
2 Basic - No local controls station							
3 Option local control station							
Valve running indication - Option Blinker							
2 Standard Switch mechanism							
6 Standard Switch mechanism + Blinker							
Option Add on Pak - Configuration*							
0 No auxiliary contacts, No potentiometer							
1 6 auxiliary switches + potentiometer							
2 Potentiometer only							
3 6 auxiliary switches							
5 2 auxiliary switches							
6 2 auxiliary switches + potentiometer							
Analogue remote position indication 4 to 20mA - Option CPT*							
0 Basic - no analogue indication							
3 Customer powered analogue 4-20mA current position transmitter (CPT)							
Analogue remote position indication 4 to 20mA - Option CPT*							
0 Basic							

Note: The CPT option requires a potentiometer and therefore the 4th digit must be a 1, 2 or 6 depending on the AS switch requirement

* 1st digit of the number code must be set to "4" if AOP auxiliary switches/potentiometer and/or CPT are required.

AWT SyncroPAK - Control & Indication Specification

Integral motor control - AWT Syncropak

AWT SyncroPAK actuators incorporate the motor starter and local controls as well as position and torque limit switches and indication switches. This allows considerable economy of site wiring due to the motor starter control assembly being an integral part of the actuator.

The SyncroPAK arrangement allows the essential elements of the valve control system to be factory tested and sealed prior to actuator despatch. In addition, SyncroPAK control includes essential protection features such as phase rotation protection – Syncrophase.

The valvemaker can carry out valve testing, requiring only a 3-phase power supply. Factory acceptance testing of the motorised valve can be simply carried out with no risk of incorrect motor control wiring causing valve or actuator damage.

SyncroPAK AWT actuators are double sealed IP68 as standard. Control, indication and 3-phase power connections are made within a separately sealed terminal compartment. Refer to page 12 for wiring diagram.

Standard features

Control package – SyncroPAK 1600

‘M’ Series Comprising integral local controls selector, actuator control transformer, reversing contactors and associated control and protection circuitry.

Local Controls

Comprising padlockable local-stop-remote selector (6mm hasp padlock) plus centre sprung local open and local close selector. Selectors are shrouded by the cover for protection.

Control transformer

Provides actuator control circuit and contactor coil supply plus a customer 24V DC supply rated at 3W for actuator fed remote control circuits. (110V AC supply available as an option – refer to optional equipment).

Contactors

Mechanically and electrically interlocked reversing contactors with auxiliary contacts, providing motor running indication.

Actuator Remote control

Standard SyncroPAK provides opto-isolated “open”, “close” and “maintain/stop” inputs for remote control within the range 19–60V DC. Typical input current at 60V is 6mA per input. For additional control inputs and ranges, refer to the Extended Remote Control Module (ERCM) page 11.

Internal remote control supplies

Standard internal supply is 24V DC (nominal) rated at 3W available to power remote control circuits.

Optional 110V AC (nominal) rated at 9VA is available. Refer to AWT SyncroPAK options, page 11.

Actuator Monitoring

“Actuator available” monitor relay with volt free changeover contact rated at 5A, 30V DC/120V AC. The monitor relay will de-energise under any one or more of the following:

- Control selector set to Local or Stop
- Motor thermostat tripped
- Main or internal power supply failure

Actuator protection

Phase rotation correction by Syncrophase™

The actuator will always run in the correct direction irrespective of supply rotation. Clockwise or anticlockwise to close direction is Dil switch selectable.

Instantaneous reversal protection

500ms delay in contactor changeover automatically applied when actuator control is instantaneously reversed. This feature protects the contactor from high switching transients.

Stayput priority

This feature will cause the actuator to “stayput” in the event of 2 control signals being applied simultaneously.

Motor thermostat

Embedded in the motor end windings, the thermostat is connected in the actuator control circuit. In the event of the thermostat tripping, operation will be inhibited until the motor cools down – auto reset on motor cooling. The thermostat may be bypassed when ESD operation is selected.

Heater

8W heater fitted as standard. The heater is switched on when main power is applied to the actuator.

Switch Mechanism

Provides torque switch protection, limit and auxiliary indication switches. Standard 3 position local indication with illuminated dial – green closed yellow intermediate and red open as standard. Refer to page 6 for detail and page 12 for SyncroPAK wiring diagram.

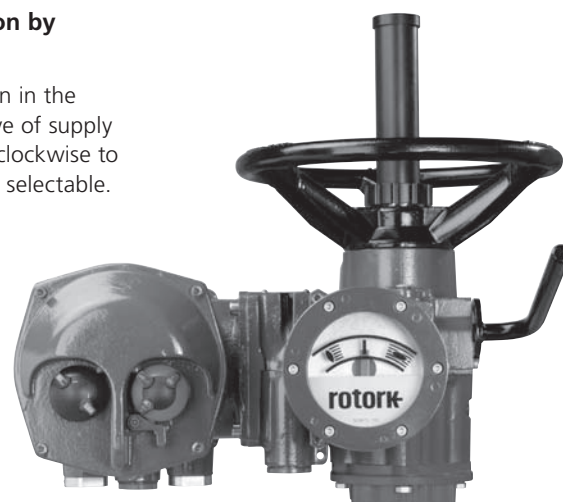

AWT SyncroPAK - Options

Option extended remote control module (ercm)

110V AC control

Remote control from supplies in the range 60–120V AC are available via the “high common”, terminals 40 & 45.

ESD

An applied ESD signal will override any existing local or remote control signal.

The ESD Direction can be set for close or open. The default direction for ESD is close. Open on ESD can be selected via a ERCM mounted DIL switch. Refer to page 14.

The ESD signal must be derived from a “stayput” contact.

The motor thermostat is bypassed during ESD (default).

Thermostat protection during ESD may be enabled via a ERCM mounted DIL switch. Refer to page 14.

ESD remote control circuits can be added to any of the standard control forms.

Refer to page 15 for ERCM remote control circuits.

Interlocks

When the ERCM is supplied the interlock inputs will be shorted out by links fitted at the terminal block.

By removing the links and connecting the permissive circuits as shown on page 15 plant interlocking such as steam valve main and bypass can be achieved. Interlocks are active in both local and remote control.

Option 110V AC Customer supply

110V AC supply (nominal) rated at 9VA available for actuator fed remote control. Note 110V AC customer supply option will be supplied with the ERCM option.

Additional valve indication – Option Add on Pak

The Add on Pak provides local mechanical valve indication plus a range of indication auxiliary switch and remote analogue valve position indication options. For further information on the Add on Pak refer to page 4.

AS1 – AS6 can be set to operate at any position through or at end of travel by cam adjustment. AS switches can be configured as NO or NC by adjusting cam to operate switch or release switch.

Remote analogue valve position, 4 to 20mA - Option CPT

Actuator or user supplied (14-40V DC), the CPT output is proportional to valve position. Maximum external impedance at 15V DC supply is 500 Ohms. The CPT is Add on Pak mounted, driven by a potentiometer with zero and span adjustment giving a range between 3.22–30mA.

Blinker

Valve running indication is available as an option via a make/break volt free contact. Refer to Add-on-Pak, page 6.

Local Control

The default for local control is maintained. Push to run control can be selected via a main PCB mounted DIL switch.

Refer to page 14.

Direction to Close

The default direction to close is clockwise. Anti-clockwise closing must be specified at time of order.



SyncroPAK double sealed terminal compartment.

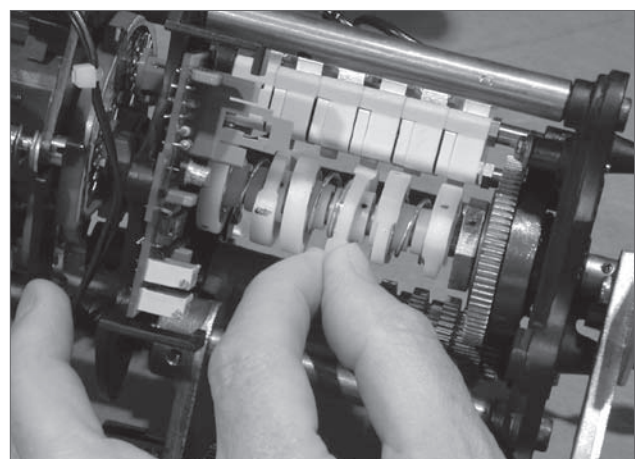

AOP with CPT - switch adjustment

AWT SyncroPAK - Basic Wiring Diagram 1610M00

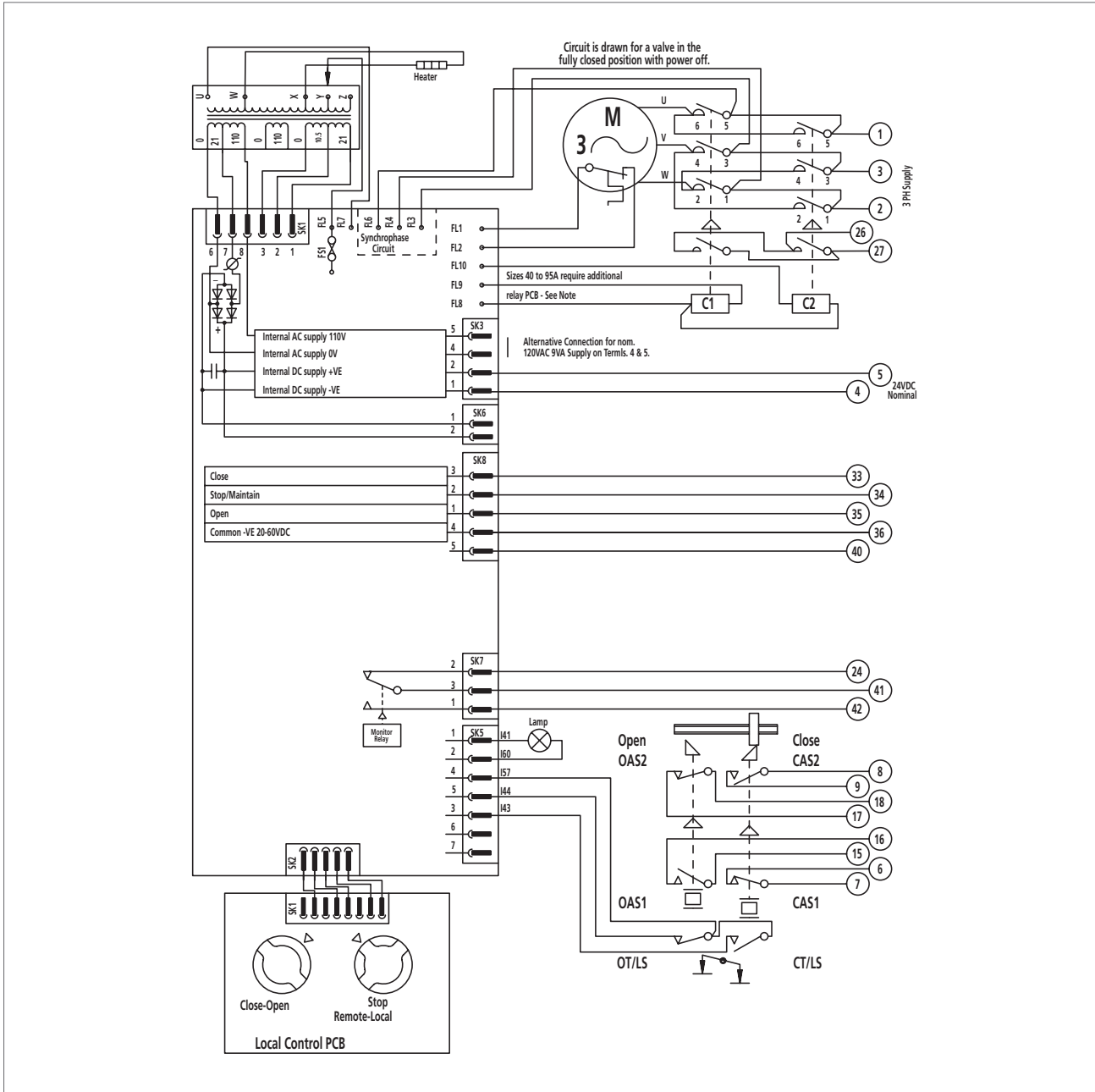

Notes:

- User connection terminal
- Link Supplied By Rotork

FS1 – 150mA Anti-surge

Customer supply
 Max load on 24V (nominal) supply terminals 4 & 5 to be 3W.
 Max load on 120V (nominal) optional supply terminals 4 & 5 to be 9VA.

Remote controls

Maximum "OFF" voltage = 5V
 Minimum control signal duration = 300ms

Switch Mechanism (refer to page 3)

- O = Open position
- C = Close position
- T/LS = torque/Limit Switch
- = contact made

Switch	Valve Open	Intermediate	Valve Close
OT/LS		■	■
CT/LS	■		
OAS1	■		
CAS1			■
OAS2		■	■
CAS2	■		

AWT SyncroPAK - Wiring Options & Number Code

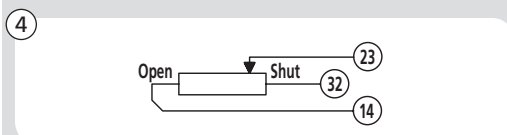
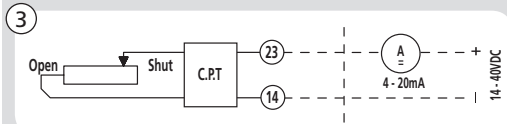
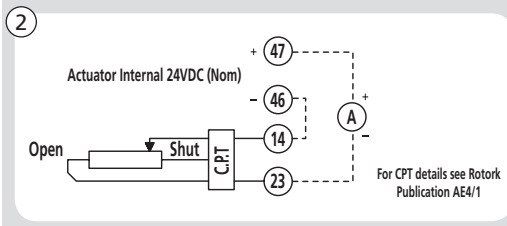
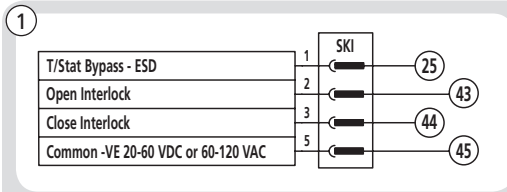

Control and indication options shown can be added in any combination to the standard wiring diagram shown opposite.

To find the correct number for the selected option combination, refer to the wiring diagram matrix selector below.

- 1 - Extended remote control module (ERCM)
- 2 - AOP - 4-20mA CPT (internal)
- 3 - AOP - 4-20mA CPT (external)
- 4 - AOP - Potentiometer
- 5 - AOP - Blinker
- 6 - AOP - 6 Auxilliary switches
- 7 - AOP - 2 Auxilliary switches

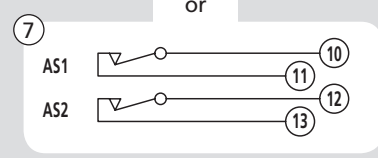
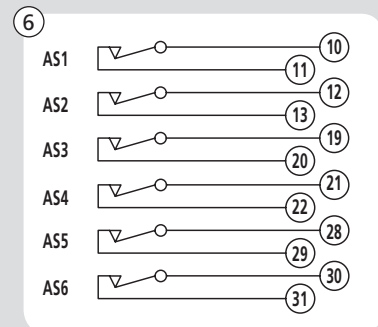
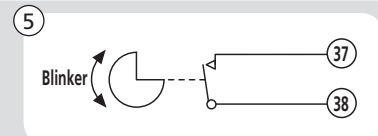

BASIC SYNCROPAK WIRING DIAGRAM 1610M00 IS SPECIFIED AS FOLLOWS:

Basic SyncroPAK comprising local control selectors, integral motor starter assembly with a standard switch mechanism (Open & close torque limit switches plus 2 open and 2 close auxiliary switches and indicator lamp), no additional auxiliary switches, potentiometer or analogue CPT are included.

Use the matrix below to select the wiring diagram for the required options.

Example: If 2 extra auxiliary switches are required the wiring diagram number changes to 1615M00.

Wiring diagram number	1	6	1	0	M	0	0
AWT SyncroPAK 0600M Series							
1 SyncroPAK							
6 1600 Series							
Switch Mechanism - Option Blinker							
1 Standard Switch mechanism							
5 Standard Switch mechanism + Blinker							
Option Add on Pak - Configuration							
0 No auxiliary contacts, No potentiometer							
1 6 auxiliary switches + potentiometer							
2 Potentiometer only							
4 6 auxiliary switches							
5 2 auxiliary switches							
6 2 auxiliary switches + potentiometer							
Analogue remote position indication 4 to 20mA - Option CPT							
0 Basic - no analogue indication							
3 Customer powered analogue (CPT)							
6 Actuator powered analogue (CPT)							
ERCM Option							
0 Standard remote control, 24V DC customer supply							
1 Extended remote control option with 24V DC customer supply							
2 Extended remote control option with 120V AC customer supply							

Note: The CPT option requires a potentiometer and therefore the 4th digit must be a 1, 2 or 6 depending on the AS switch requirement

AWT SyncroPAK - Standard Remote Control Circuits

Standard Control Forms

The remote control forms available for the standard AWT SyncroPAK are shown below.

All control inputs are opto-isolated with a surge immunity of 2KV.

Standard control is positive switching – negative switching is available.

Standard control can be internally fed using the customer 24V DC supply (nominal) available at terminals 4 & 5 or externally fed within the range 20-60V DC.

Maximum "OFF" voltage = 5V.

Minimum control signal duration = 300ms.

The current drawn by each input is 6mA (max).

Selectable functions

Standard SyncroPAK		
DIL switch	'ON'	'OFF'
1	Clockwise closing	Anti-clockwise closing
2	Local maintained control	Local push-to-run control

ERCM		
DIL switch	'ON'	'OFF'
1	Thermostat bypassed during ESD	Thermostat enabled during ESD
2	Close on ESD	Open on ESD

Unless otherwise specified, actuators will be despatched with DIL switches set to 'ON'.

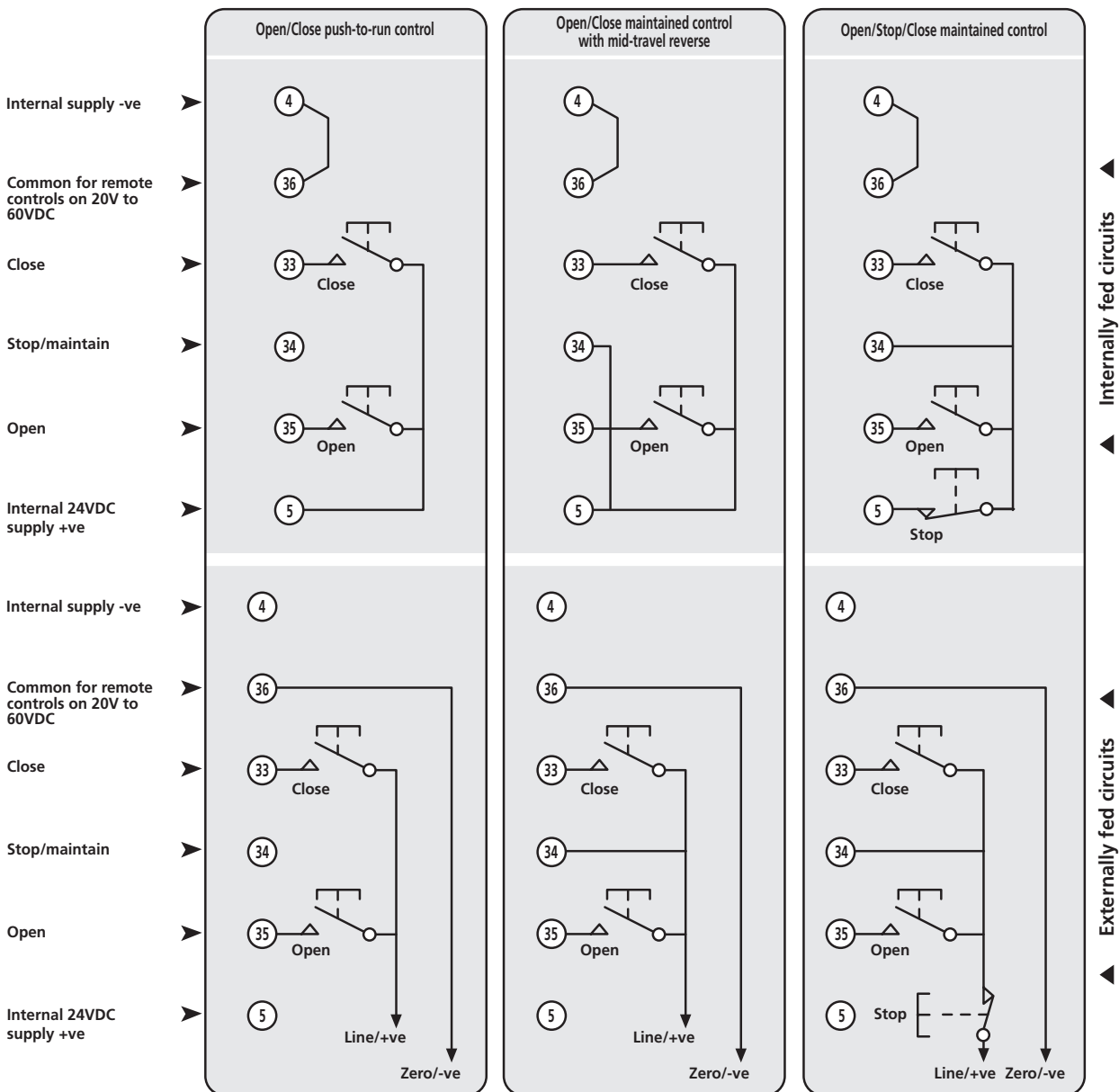

AWT SyncroPAK - Standard Remote Control Circuits

OPTION ERCM

Remote control forms available with the addition of the ERCM are shown below. For remote control input specification refer to standard control forms on page 14.

Refer to page 11 for ERCM details.

For ERCM internally fed remote control circuits refer to Standard, internally fed circuits on page 14. Link 4-40 for internally fed ERCM control circuits.

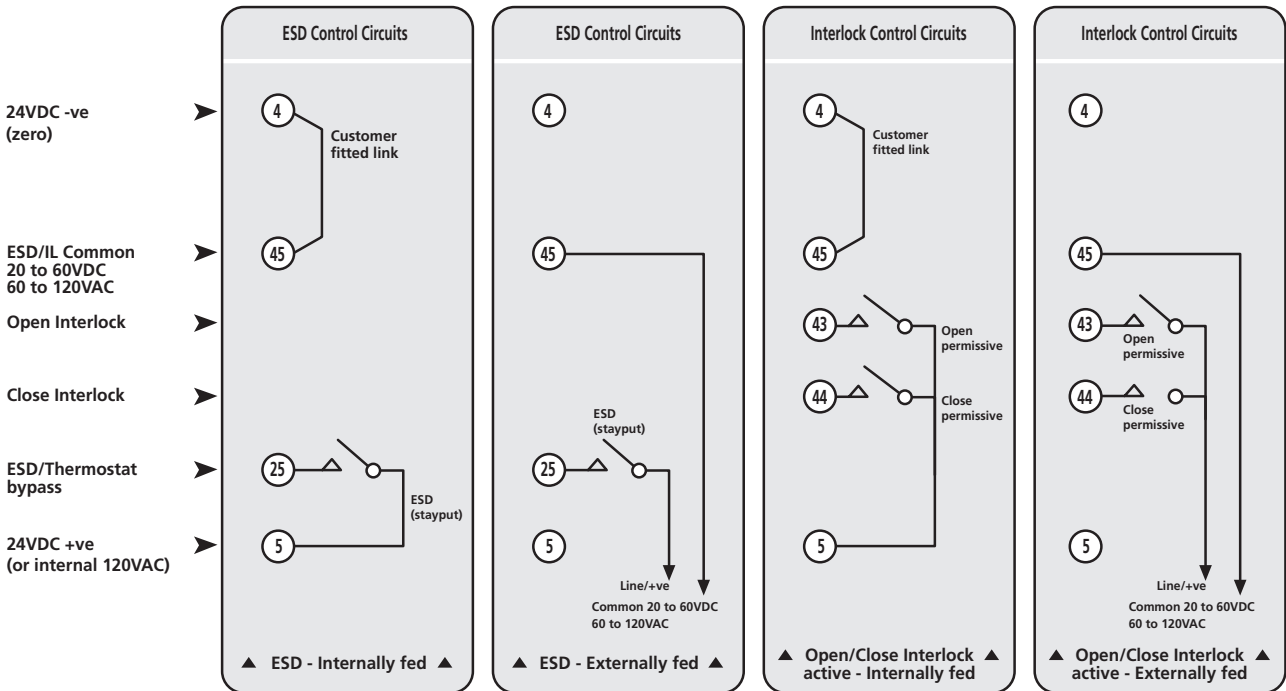
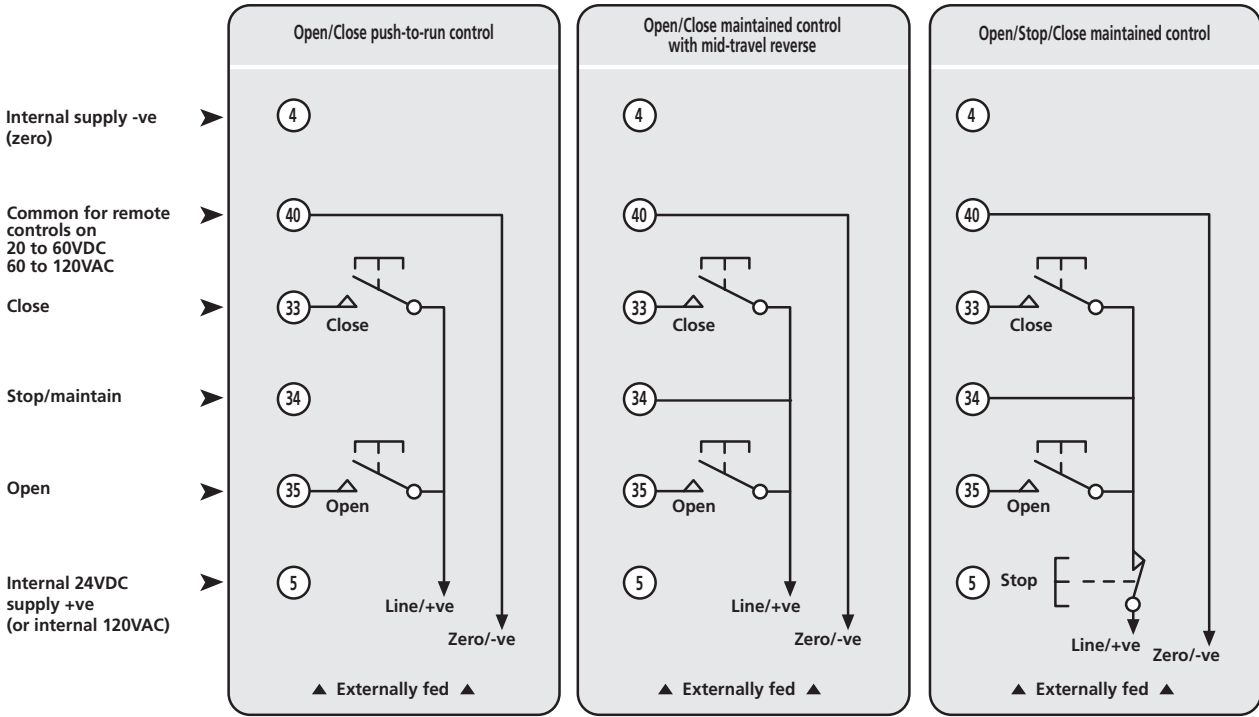



Rotork Controls Inc, Rochester, USA



Rotork Controls Ltd, Bath, UK

As part of a process of on-going product development, Rotork reserves the right to amend and change specifications without prior notice. Published data may be subject to change. For the very latest version release, visit our website at www.rotork.com. The name Rotork is a registered trademark. Rotork recognises all registered trademarks. Published and produced in the UK by Rotork Controls Limited. POWSH0908

rotork® Controls

UK head office
Rotork Controls Limited
tel Bath 01225 733200
fax 01225 333467
email mail@rotork.co.uk

USA head office
Rotork Controls Inc
tel Rochester (585) 247 2304
fax (585) 247 2308
email info@rotork.com

A full listing of our worldwide sales and service network is available on our website at:

www.rotork.com

Controls
Electric Actuators and Control Systems

Fluid Systems
Fluid Power Actuators and Control Systems

Gears
Gearboxes and Gear Operators

Site Services
Projects, Services and Retrofit